

HEATING ELEMENT FOR OIL HEATING

low loading W/cm²
500-12 500W

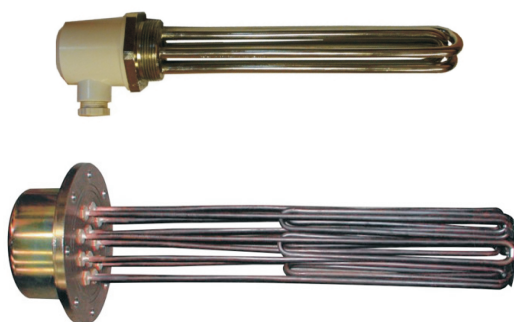

DESCRIPTION:

- flange material: brass, steel, stainless steel 17 240/1.4301; 17 346/1.4401
- rod material: copper, steel, stainless steel 17 240/1.4301; 17 346/1.4401
- threaded, flange design, with inbuilt regulation TRG

APPLICATION:

- hydraulics
- industrial control systems
- rail vehicles
- railway switches

TECHNICAL PARAMETERS

- power: 500-12 500W
- connection: threaded M48x2, G6/4", flange DIN 2501, EN 1092-1, ANSI B16,5, individual
- regulatory range/ T fuse: 0-40°C/55°C; 7-77°C/99°C; 20-127°C/150°C; 30-85°C/110°C; 50-150°C/180°C
- power supply 120, 230, 400, 480, 500V
- atypical adjustments: increased IP, inbuilt el. control, control by inbuilt thermostat, limit switches etc.
 - individual rods length and shape adjustments
 - PN: 0,6-6,4MPa
 - protection: IP 54

SPECIFICATION:

Heating elements for oil heating are specially modified tube elements, that ensure, that there is no oil or similar heated liquid carbonization on the surface or the element. Heating elements feature surface load within interval 1,4-2W/cm², that guarantees sufficient and safe heat transfer. It is also possible to produce elements with individual adjustments and lower/higher W/cm² loading requirements.

Commonly used materials for flanges are brass and nickel-plated steel, for heating rods carbon steel or stainless steel.

Power supply of the heating rods is optional and will be supplied according to customer requirements 110V, 230V, 400V, 480V, 500V, most commonly 1x230V or 1x400V (for single rod design) and 1x230V, 3x230V, 1x400 and 3x400V (for multi rod design).

Heating elements may be supplied with modifications according to customer requirements.

HEATING ELEMENT WITH REGULATION FOR OIL HEATING

type TRG 11
500-2 250W

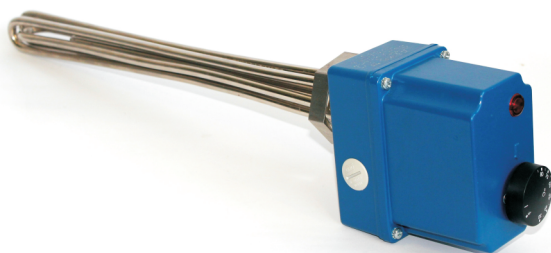

DESCRIPTION:

- heating element with inbuilt regulation including thermal fuse
- connection material: steel, brass, stainless steel 17 248/1.4541
 - rod material: steel, brass, stainless steel 17 248/1.4541, Incoloy 800

APPLICATION:

- hydraulic industry
- mechanical engineering
 - food industry
 - pharmaceutical industry
 - paper industry

TECHNICAL PARAMETERS:

- power: 500, 750, 1 000, 1 250, 1 800, 2 250W
- regulatory range/ T fuse: 0-40°C/55°C; 7-77°C/99°C; 20-127°C/150°C; 30-85°C/110°C; 50-150°C/180°C
 - thread: M48x2, G6/4 or individual
 - power supply: 230/400V
 - protection: IP 54

SPECIFICATION:

Heating elements consist of two parts. The heating part is made of three U-shaped steel heating rods, that are connected to the head by thread M48x2 or G11 ". Terminal board is made of Al cast with protection IP 54. Another parts or the element are regulatory thermostat (capillary) with thermal fuse, that protects the heating element from overheating, glow tube indicating the mode (heating/not heating) and a regulatory knob with marked scale. Electric supply is possible from both sides through OBO-VTEC bushing.

Heating element is designed for direct oil and similar liquid heating. The element is specially modified to ensure there is no oil or similar heated liquid carbonization. During operation, the heating rods must be fully immersed in the liquid up to the head. Suitable in operations that require instant liquid temperature regulation.

Power (W)	Supply (V)	L (mm)	Connection thread	Material	Range/thermal fuse
500	230/400	300	M48x2, G 6/4'' atypical connections: G5/4'', Clamp 100, flanges according to DIN	steel, stainless steel 17 248/1.4541, Incoloy 800	0-40°C / 55°C 7-77°C / 99°C 20-127°C / 150°C 30-85°C / 110°C 50-150°C / 180°C
750	230/400	340			
1000	230/400	580			
1250	230/400	680			
1800	230/400	820			
2250	230/400	980			

Customization on request: - shortened design
 - material treatment and surface finish of the submersible rods
 - individual colour or the control terminal board
 - customized control (electronic thermostat, sensor Pt100, thermal fuse only etc.)

Order code

Power Range / thermal fuse Thread Screw Connect. mater. TRG material Individual

Code	power: write down in W determine from 500-2250W
Code	range / thermal fuse
1	0-40°C / 55°C
2	7-77°C / 99°C
3	20-127°C / 150°C
4	30-85°C / 110°C
5	50-150°C / 180°C
Code	thread
M48	M48x2
G6/4''	G6/4''
O	other
Code	screw
1	ANO
2	NE

Code	Connection material
M	brass
N	stainless steel 17 248/1.4541
O	other
Code	rod material
M	brass
N	stainless steel 17 248/1.4541
I	Incoloy 800
Code	individual
N	individual non-heating part
P	surface finish
T	other temperature ranges
O	other - specify

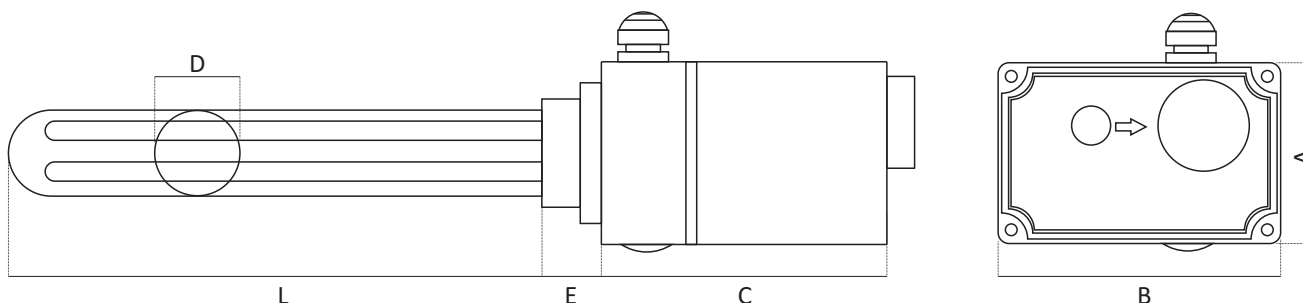

Dimensions in mm						
	A	B	C	D	E	L
TRG 11	80	125	120	38	22	290, 310, 335, 435, 610, 670, 810

Heating element 1 - rod type 230V

Type: 14070, A4....

SPECIFICATION:

Heating element consists of one steel heating branch made in required shape and length which is connected to the brass head with lid (protection IP 54) and with el. bushing PG13,5. Flanges attachment hexagon size OK 65. Heating element designed for direct oil heating. Output surface load should be selected in a way, so that oil carbonisation does not take place. Working pressure 0,6MPa.

DESCRIPTION:

- heating rods: steel
- flange: brass
- PN: 6bar



TECHNICAL PARAMETERS:

Type		Supply (V)	Power (W)	L (mm)	Thread
1407090020	A4546	1x230	500	300	M48x2 G6/4"
1407090010	A4545	1x230	750	450	
1407090040	A4544	1x230	1000	580	
1407090060	A4547	1x230	1250	680	
1407090050	A4621	1x230	1800	820	
1407090030	A4820	1x230	2250	980	

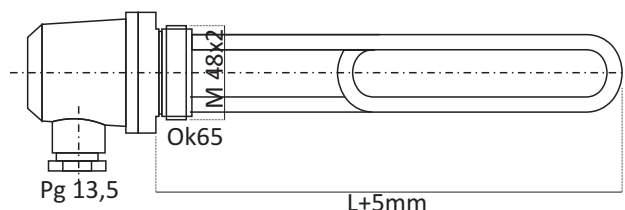

Heating element 3 - rod type

Type: 14011, A4...

SPECIFICATION:

Heating element consists of three heating rods made in required shape and length connected to the brass head with lid (protection IP 54) and with el. bushing PG13,5. Flanges attachment hexagon size OK 65. Heating element designed for direct oil heating. Output surface load should be selected in a way, so that oil carbonisation does not take place. Working pressure 0,6MPa.

DESCRIPTION:

- heating rods: steel
- flange: brass
- PN: 6bar



TECHNICAL PARAMETERS:

Type		Supply (V)	Power (W)	L (mm)	Thread
1401193940	A4770	2x230/400V	500	300	M48x2 G6/4"
1401193860	A4609	2x230/400V	750	340	
14011	A4550	3x230/400V	1000	580	
1401194130	A4553	3x230/400V	1250	680	
1401194140		3x400V	1800	820	

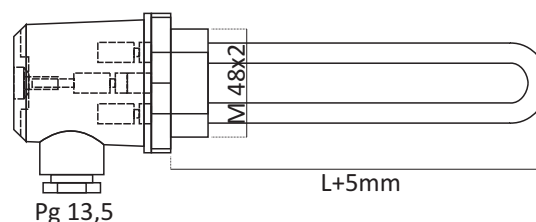

FLANGE HEATING ELEMENTS up to 12 500W

type 14211 / 4411
2 500-12 500W



DESCRIPTION:

- steel cover of terminal board IP 44
 - heating rods: copper, steel, stainless steel 17 240/1.4301; 17 346/1.4401
 - flange: galvanized steel, stainless steel 17 240/1.4301; 17 346/1.4401
- flange DIN 2501, EN 1092-1, ANSI B16,5, individual

APPLICATION:

- hydraulics
- mechanical engineering
 - food industry
 - pharmaceutical industry
 - paper industry

TECHNICAL PARAMETERS:

- power: 2 500, 3 500, 4 000, 5 500, 7 000, 8 000, 10 000, 12 500W, individual
 - supply: 120, 230, 400, 480, 500V
- atypical adjustments: increased IP, inbuilt el. control, control by inbuilt thermostat, limit switches etc.
 - individual rods length and shape adjustments
 - pressure load: PN 0,6 / 1,0 / 2,5 / 6,4MPa

SPECIFICATION:

Heating elements are designed for water, oil and similar liquid heating and are adjusted in a way, so that they do not cause oil carbonisation. Heating elements must be fully immersed in the liquid during operation.

Max. permissible pressure 0,6; 1; 2,5 and 6,4MPa. Heating elements with submersible length over 700mm should be supported. Flange heating elements consist of nickel-plated steel flange (according to DIN 2501, EN 1092-1, ANSI B16,5/ alternatively on customers request) and three heating rods. Ceramic terminal board is protected by a steel cover with el. bushing GP21/18, ensuring IP 42.

Type	Supply (V)	Power (W)	L (mm)		
1421190020	441191010	3x400	2500	400	steel rods
1421190030	441191060	3x400	6000	700	steel rods
1421190040		3x400	10000	1000	steel rods
1421190050	441191090	3x400	12500	1250	steel rods
1421190060	441191040	3x480	4000	600	steel rods
1421190070	441191020	3x480	3500	400	steel rods
1421190080	441191080	3x400	8000	1075	steel rods
1421190090	441191050	3x400	5500	800	steel rods
	441191410	3x500	2500	400	steel rods
	441191412	3x500	3500	400	steel rods
	441191440	3x500	4000	600	steel rods
	441191460	3x500	6000	700	steel rods
	441191470	3x500	7000	950	steel rods
	441191480	3x500	8000	1075	steel rods
	441191490	3x500	12500	1250	steel rods
<p>0 - determines PN 0,6MPa for design 3x400V 1 - determines PN 1,0MPa for design 3x400V 2 - determines PN 2,5MPa for design 3x400V 3 - determines PN 6,3MPa for design 3x400V 4 - determines PN 0,6MPa for design 3x500V 5 - determines PN 1,0MPa for design 3x500V</p>					

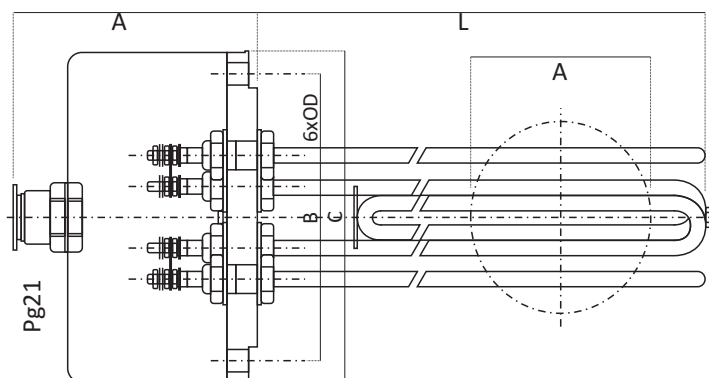
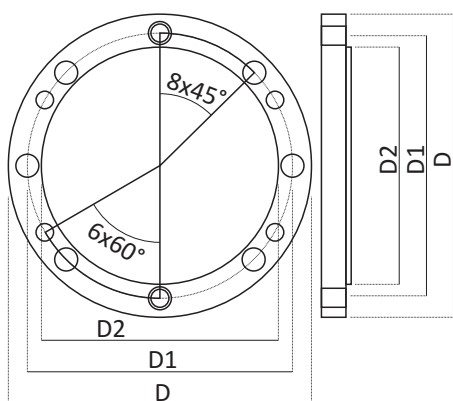

Dimensions of connection flange according to PN					
PN(MPa)	D(mm)	D1(mm)	A(mm)	Screw	Testing pressure MPa
1,0	182	158	14	6xM12	1,3
Dimensions in mm					
A	B	C	D	E	
155	158	182	13	106	

Customization on request:

Power supply: 120, 230, 400, 480, 500 V; Shape and length of heating rods: on individual request; Heating rods material: copper, steel, stainless steel 17 240/1.4301; 17 346/1.4401, teflon-plated; Flange design: flange according to DIN 2501, EN 1092-1, ANSI B16.5; Flange material: galvanized steel, stainless steel 17 240/1.4301; 17 346/1.4401;

Atypical customization: increased IP protection, inbuilt el. control, control by inbuilt thermostat, limit switches, etc.