

# ŠKRTICÍ VENTIL STU



### SPECIFIKACE:

- škrťací ventily se používají k regulaci průtoku médií
- velikost je závislá na průtoku, teplotě a rychlosti proudění

### TECHNICKÉ PARAMETRY:

- nejvyšší tlak: 40MPa
- max. průtok: 150l/min

### SYMBOL:

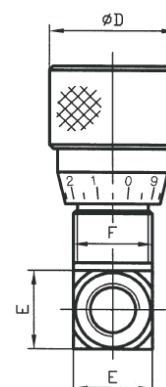
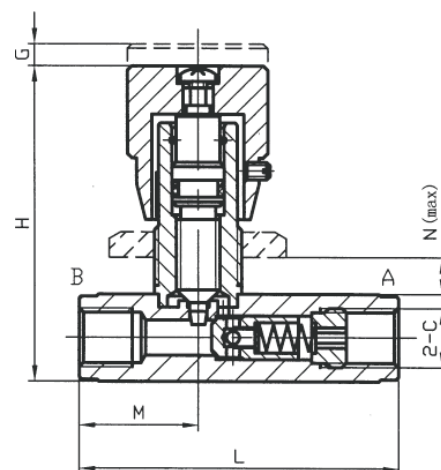
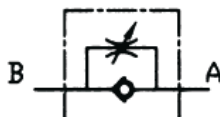

Typ	Rozměry (mm)									Max. tlak MPa	Max. průtok l/min
	C	L	H	D	E	F*	G	M	N		
STU0400	1/4"	73	72	32	20	M20x1	5	27	7S	50	20
STU0600	3/8"	82	80	32	25	M25x1,5	9	31	7	50	45
STU0800	1/2"	98	92	45	30	M30x1,5	9	36,5	9	50	80
STU1200	3/4"	112	100	45	40	M35x1,5	10	42	11	35	110
STU1600	1"	142	122	45	45	M40x1,5	12	51	15	30	150