

SHOCK RESISTANT PRESSURE GAUGE 304G/ 358G

diameters 63mm
bottom, back connection
glycerine filling

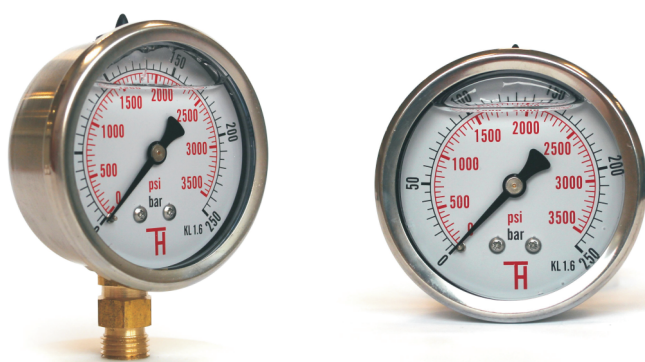

DESCRIPTION:

- bayonet case / encased stainless steel 17 240/1.4301
 - safety glass inspection hole, acrylate
 - connection 304G (bottom), 358G (back) CuZn and copper alloys
- measure mechanism CuZn and copper alloys

APPLICATION:

- heating industry
- air-conditioning
 - hydraulics
- mechanical engineering
- petrochemical industry

TECHNICAL PARAMETERS:

- diameter: 63mm
- measure ranges: 0-100, 160, 250, 400, 600kPa
0-1; 1,6; 2,5; 4; 6; 10; 16; 25; 40; 60; 100MPa
 - scale: Pa, bar, bar/psi, individual
- connection thread: G1/4 (M12x1,5, NPT)
 - accuracy class: 1,6%
- design: pressure gauge, pressure-vacuum indicator, vacuum indicator

SPECIFICATION:

Shock resistant pressure gauges 304G/358G are produced according to standard EN837-1. Mainly used for simple pressure measurement of liquids, vapour and gases, that do not have a corrosive effect on copper alloys and its viscosity allows for measuring using bourdon pen mechanism.

Shock resistant pressure gauges with water-tight case are designed into harsh conditions, where the pressure gauge is exposed to vibration, humidity and other complicating conditions. Resists vibration, shocks and pressure surges for which purpose they are equipped with pressure shock absorbers. Supplied with encased design or bayonet case. Environment temperature -40 up to 60°C , medium temperature $T_{\text{max}} 60^{\circ}\text{C}$. Other design options on request - special scale design, connection threads, max. pressure needle, etc.

Code	304G	358G
Diameter	63mm	
Design	bottom connection	back connection
Accuracy class	1,6 %	
Ranges	0-60kPa...0- 100MPa, vacuum and pressure	
Highest accuracy	constant pressure - 3/4 from all range ,fluctuating pressure - 2/3 from all range	
Case	stainless steel 17 240/1.4301	
Ring	stainless steel 17 240/1.4301 - encased/bayonet	
Inspection hole	plexiglass / glass	
Scale	white Al sheet with black print according to DIN 16 109	
Needle	black sprayed Al sheet	
Machine basis	CuZn - alloy	
Spring	Cu - alloy	
Connection	CuZn -alloy	
Thread	G1/4 (M12x1,5,NPT, BSP)	
Medium temper.	T_{max} 60°C	
Environment temp.	T_{min} -40°C, T_{max} 60°C	
Measuring depend. on temperature	0,3%/10K for deviation from normal temperature 20°C	
Weight approx.	0,21kg	0,26kg

- 304G bayonet - bottom connection • 358G - back connection - with front flange - with clamp

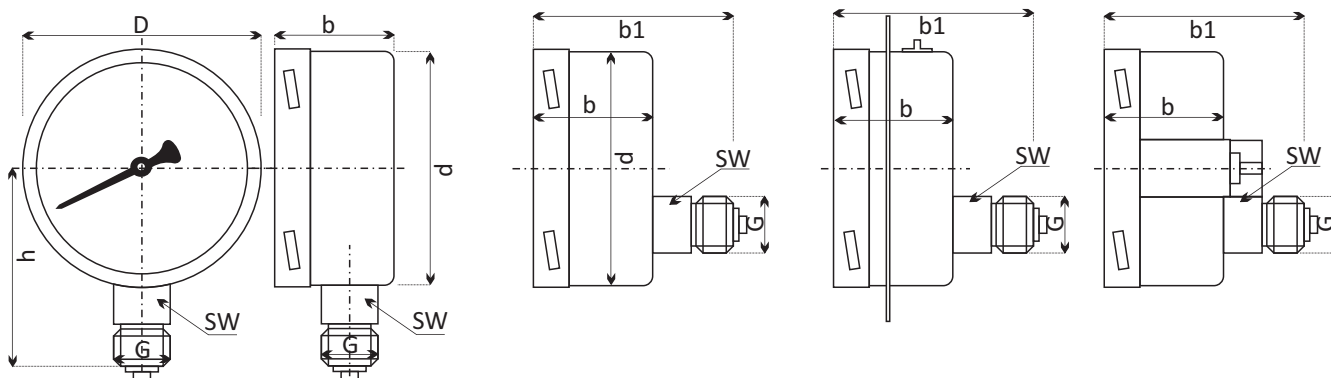

Dimensions in mm								
Type	Nom. size	d	b	b1	D	G	h	SW
304G	63	62	32	-	64	G1/4	52	14
358G	63	62	32	62	64	G1/4	-	14

- 304G encased -bottom connection • 358G - back connection - with front flange - with clamp

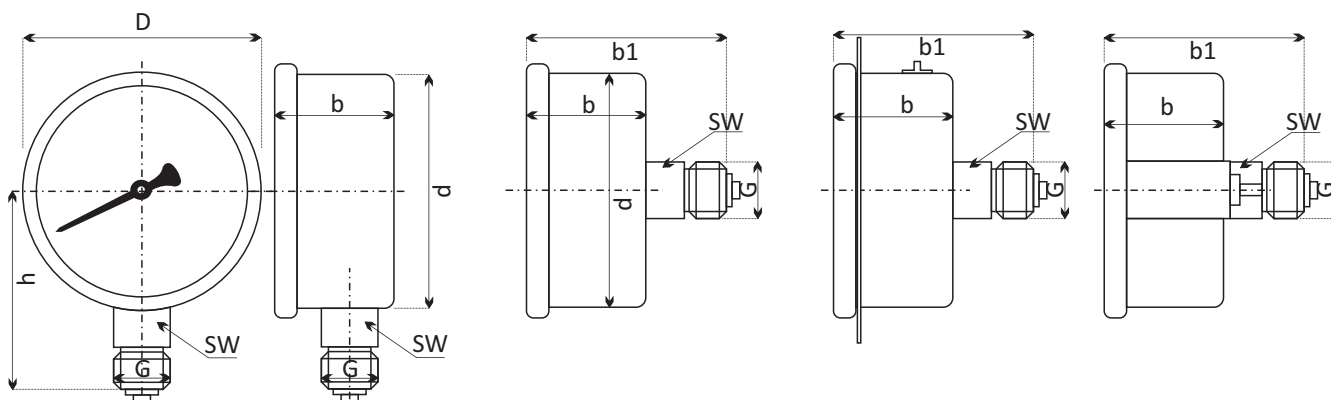

Dimensions in mm								
Type	Nom. size	d	b	b1	D	G	h	SW
304G	63	62	30	-	61	G1/4	56	14
358G	63	62	30	60	61	G1/4	-	14

