



SHOCK RESISTANT PRESSURE GAUGE 310G/320G

diameter 80mm
bottom, back connection
glycerine filling

DESCRIPTION:

- encased stainless steel case 17 240/1.4301
 - acrylate inspection hole
- connection 310G (bottom); 320G (back)
CuZn and copper alloys
- measuring mechanism CuZn and copper alloys

APPLICATION:

- heating industry
- air-conditioning
 - hydraulics
- mechanical engineering
- petrochemical industry

TECHNICAL PARAMETERS:

- diameter: 80mm
- measure ranges: 0-60, 100, 160, 250, 400, 600kPa
0-1; 1,6; 2,5; 4; 6; 10; 16; 25; 40; 60; 100MPa
 - scale: Pa, bar, bar/psi, individual
- connection threads: G1/2 (M20x1,5, NPT)
 - accuracy class: 1,6%
- design: pressure gauge, pressure-vacuum indicator,
vacuum indicator

SPECIFICATION:

Shock resistant pressure gauges 310G/320G are produced according to standard EN837-1. Mainly used for simple pressure measurement of liquids, vapour and gases, that do not have a corrosive effect on copper alloys and its viscosity allows for measuring using bourdon pen mechanism.

Shock resistant pressure gauges with water-tight case are designed into harsh conditions, where the pressure gauge is exposed to vibration, humidity and other complicating conditions. Resists vibration, shocks and pressure surges for which purpose they are equipped with pressure shock absorbers. Supplied with encased design case. Environment temperature -40 up to 60°C, medium temperature T_{max} 80°C. Other design options on request - special scale design, connection threads, max. pressure needle, lazy needle etc.

Code	310G	320G
Diameter	80mm	
Design	bottom connection	back connection
Accuracy class	1,6 %	
Ranges	0-60kPa...0- 100MPa, vacuum and pressure	
Highest accuracy	constant pressure - 3/4 from all range ,fluctuating pressure - 2/3 from all range	
Case	stainless steel 17 240/1.4301	
Ring	stainless steel 17 240/1.4301 - encased	
Inspection hole	acrylate	
Scale	white Al sheet with black print according to DIN 16 109	
Needle	black sprayed Al sheet	
Machine basis	CuZn - alloy	
Spring	Cu - alloy	
Connection	CuZn -alloy	
Thread	G1/2 (M20x1,5)	
Medium temper.	T _{max} 80°C	
Environment temp.	T _{min} -40°C, T _{max} 60°C	
Measuring depend. on temperature	0,3%/10K for deviation from normal temperature 20°C	
Weight approx.	0,4kg	0,4kg

- 310G encased - bottom connection
- 320G - back connection - with front flange - with clamp

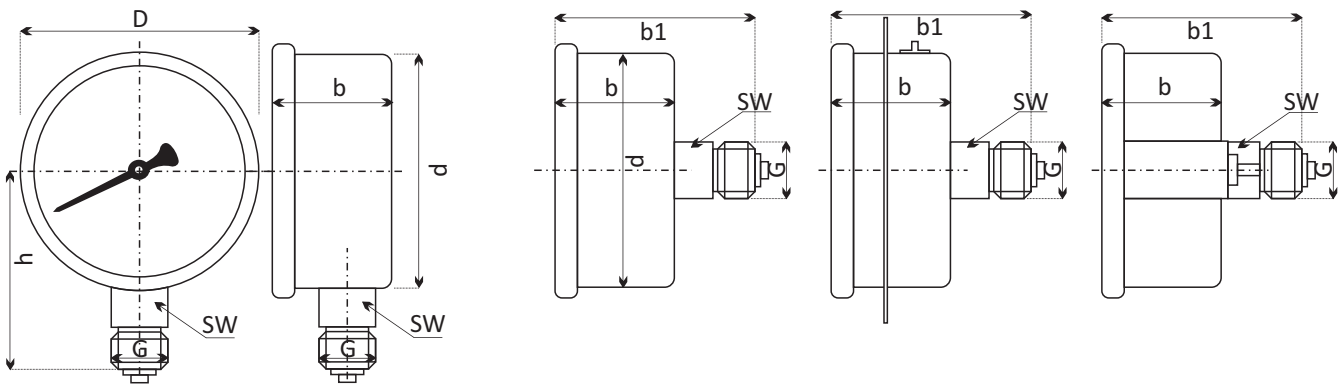

Dimensions in mm								
Type	Nom. size	D	b	b1	d	G	h	SW
310G	80	81,6	30	-	75	G1/2, M20x1,5	71,5	22
320G	80	81,6	30	65	75	G1/2, M20x1,5	-	22