

SELECTIVE VALVE VU/SF



SPECIFICATION:

- selective valve is used in piping for selection of the higher pressure from two pressure branches

TECHNICAL PARAMETERS:

- max. pressure: 50MPa
- max. flow: 150l/min

SYMBOL:

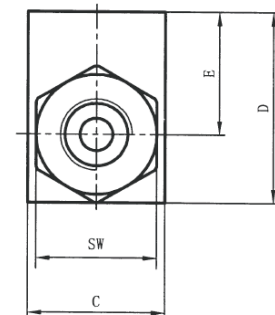
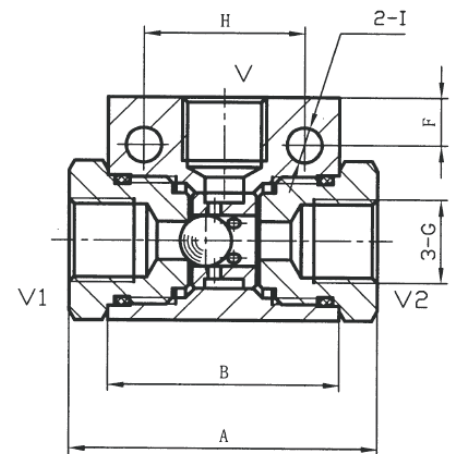
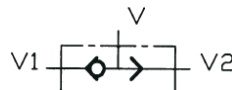

Type	Dimensions (mm)										Max. pres. MPa	Max. flow l/min
	A	B	C	D	E	F	G	H	I	SW		
VU/SF-01-1/4	48	36	25	35	22,5	7,5	1/4"	25	5,5	22	50	20
VU/SF-02-3/8	59	45	30	45	30	8	3/8"	29	6,5	27	50	45
VU/SF-03-1/2	90	57	35	50	32,5	8,5	1/2"	36	6,5	32	50	80
VU/SF-04-3/4	113	62	45	60	37	6,5	3/4"	50	8,5	41	35	110
VU/SF-05-1	120	80	50	80	54,5	11	1"	60	10,5	46	30	150